



RENTH

MT-X1440

TECHNICAL DATA SHEET



 **MANITOU**
www.manitou.com





RENTH

MT-X1440

	MT-X 1440	MT-X 1440 A
Lifting		
Max. capacity		4000 kg
Max. lifting height		13.53 m
Reach at max. height		1.13 m
Break-out force with bucket	8000 daN	8800 daN
Unladen time		
Lifting	15.5 secs	15.7 secs
Lowering	11.6 secs	13.3 secs
Extension	16.5 secs	19.2 secs
Retraction	11.9 secs	14.8 secs
Crowd		4 secs
Dump		4 secs
Tyres		400/80-24
Braking	hydraulic multiple-disk brake with oil bath on front and rear axles	
Engine	PERKINS - STAGE 3A	
Type	1104D-44TA	
Cubic capacity	4400 cm ³	
Power	101 HP/74.5 kW	
Max. torque	400 Nm - 1400 rpm	
Injection	direct	
Cooling	water	
Laden drawbar pull	8250 daN	
Transmission	torque converter	
Reversing shift	electrohydraulic control	
Number of gears (forward / reverse)	4/4	
Max. travel speed (may vary according to applicable regulations)	25 kph	
Hydraulics		
Pump	gear type with flow splitter - 170 l/min - 270 bar	
Capacities		
Hydraulic oil	175 l	
Fuel	140 l	
Unladen weight (with forks)	11115 kg	11795 kg
Dimensions		
1. Front wheel centre to carriage	1.90 m	
2. Ground clearance	0.37 m	
3. Overall length to front tyres	4.87 m	
4. Wheelbase	3.07 m	
5. Rear wheel centre to rear face	1.16 m	
6. Overall width of cab	0.89 m	
7. Inside tyre width	1.96 m	
8. Overall width	2.35 m	
9. Overall width (stabilizers lowered)	3.79 m	
10. Overall height	2.45 m	
Turning radius (over tyres)	3.97 m	
Frame levelling	+/- 9°	
Carriage rotation (crowd/dump)	12°/114°	
Noise and vibration		
Noise at driving position (LpA)	82 dB	
Environmental noise (LwA)	106 dB	
Vibration to whole hand/arm	<2.5 m/s ²	
Vibration on driver's body	0.985 m/s ²	

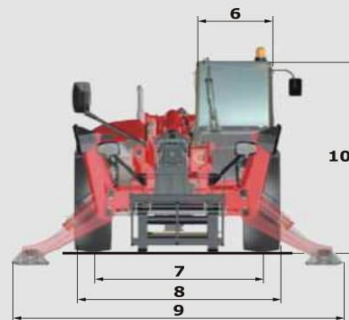
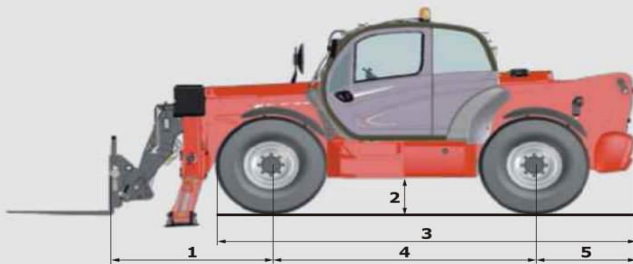



RENTH

MT-X1440

Rough Terrain Load Chart

standard EN1459 B

Machine on tyres with forks

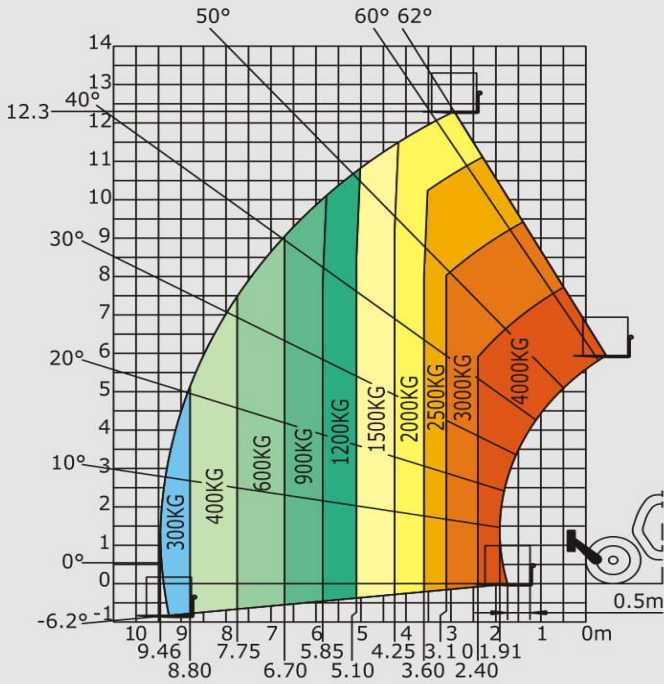

Machine on stabilizers with forks

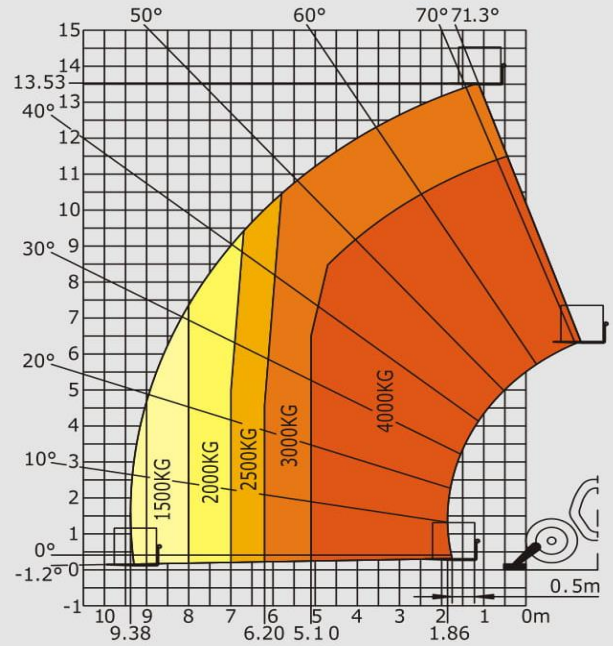

Machine on stabilizers with platform

(MT-X 1440 A versions)

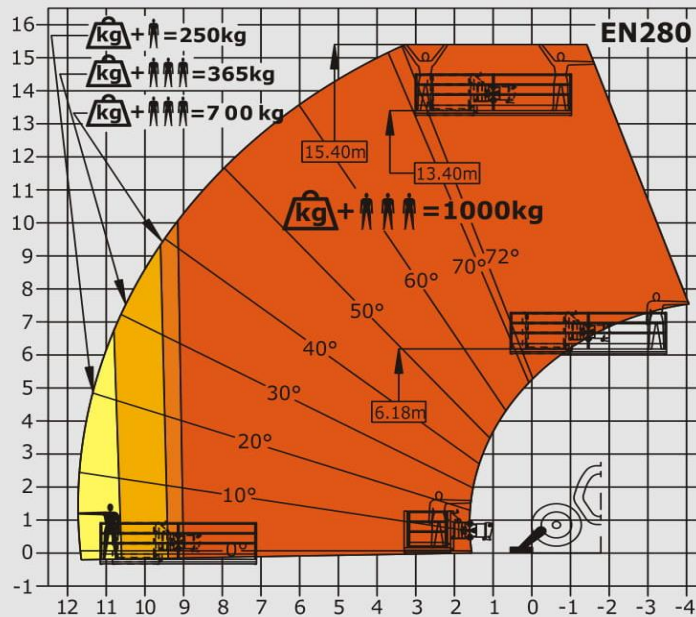

This brochure describes versions and configuration options for Manitou products which may be fitted with different equipment. The equipment described in this brochure may be standard, optional or not available depending on version. Manitou reserves the right to change the specifications shown and described at any time and without prior warning. The manufacturer is not liable for the specifications given. For more information, contact your Manitou dealer. Non-contractual document. Product descriptions may differ from actual products. List of specifications is not comprehensive. The logos and visual identity of the company are the property of Manitou and may not be used without authorisation. All rights reserved. The photos and diagrams contained in this brochure are provided for information only.

MANITOU BF SA - Limited company with board of directors - Share capital:39,547,824 euros - 857802508 RCS Nantes

