



RENTH

E450AJ ARTICULATING BOOM LIFTS

Platform

- 0.76 m x 1.52 m low mount platform
- Side entry with drop bar mid rail
- Multiple function operation
- Full proportional drive joystick control with integral thumb steer switch
- Full proportional main boom and swing joystick control
- Multiple speed control for lower boom, telescope, jib and platform rotate
- Selectable creep speed on drive / lift and swing functions
- 1.22 m articulating jib
- 180 degree powered platform rotator
- Platform console machine status light panel ¹
- Load sensing system
- AC power cable to platform

Available Options

- 0.76 m x 1.22 m low mount platform
- Side entry with inward swing gate
- 13 mm air line to platform
- Non mark solid rubber tyres
- 240/55 - 17.5 non marking foam filled tyres
- 305A/hr maintenance free AGM batteries in lieu of standard
- All motion alarm
- Alarm package ²
- Platform worklights
- Head and tail lights
- Light package ³
- Amber strobe light
- Plugs & Sockets
- Acrylic console shield
- Cylinder bellows

Power & Transmission

- Two Wheel Direct Electric Drive
- 8 x 6V 370 A/hr deep cycle batteries
- Automatic traction control
- Programmable "Personality" settings
- On-board self-diagnostic testing
- Enclosed battery / electrical compartment
- 20 amp automatic battery charger
- Automatic rear wheel brakes
- Sculptured ABS hoods

Functional Equipment & Accessories

- 3 degree tilt alarm and indicator light
- 240/55 - 17.5 foam filled tyres
- Ground control selector switch with key lock
- Lifting/tie down lugs
- Battery condition indicator
- Hour meter
- Horn
- Platform tool tray
- Manual descent system



¹ Provides indicator lights at platform control console for system distress, low battery, tilt light, and foot switch status.

² Includes all-motion alarm and amber strobe light.

³ Includes head & tail lights and platform work lights.





E450AJ ARTICULATING BOOM LIFTS

Platform Height	13.72 m
Horizontal Outreach	7.24 m
Up and Over Height	7.70 m
Swing (non-continuous)	360°
Platform Capacity – Unrestricted	230 kg
Platform Rotator (Hydraulic)	180°
Jib – Overall Length	1.24 m
Jib - Range of articulation	144° (+84°/ -60°)
A. Platform Size	0.76 m x 1.52 m
B. Overall Width	1.75 m
C. Tailswing (working condition)	Zero
D. Stowed Height	2.01 m
E. Stowed Length	6.45 m
F. Wheelbase	2.01 m
G. Ground Clearance	0.20 m
Machine weight ¹	6,670 kg
Maximum Ground Bearing Pressure	5.3 kg/cm ²
Drive Speed	5.2 km/h
Gradeability	30%
Tyres	240/55-17.5 Foam Filled
Turning Radius – Inside	0.61 m
Turning Radius – Outside	3.15 m
Electrical System	48V DC
Batteries	8 x 6V 370 A/hr
Drive Motors	Dual Electric Traction
Brakes	Automatic Spring Applied
Hydraulic Motor	Perm. Magnet
Hydraulic Pump	Gear Pump
Hydraulic Reservoir	20 L

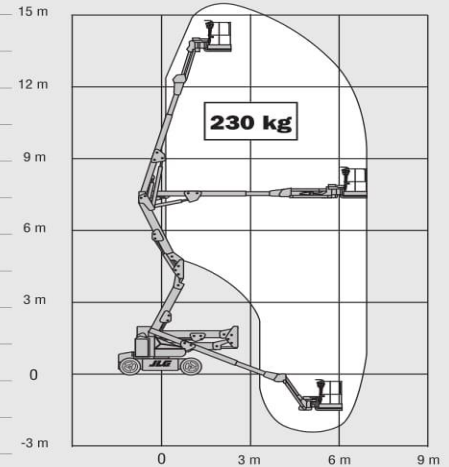

JLG Industries, Inc. is a leading designer and manufacturer of access equipment and complementary services and attachments.

JLG has manufacturing facilities in the United States, France, Romania, China and Belgium. Customers throughout Europe, Scandinavia, Africa and the Middle East benefit from a network of dedicated sales and service operations designed to deliver the highest levels of support.

JLG is an Oshkosh Corporation company.

www.jlgeurope.com

¹ Certain options or country standards may increase weight and/or dimensions.

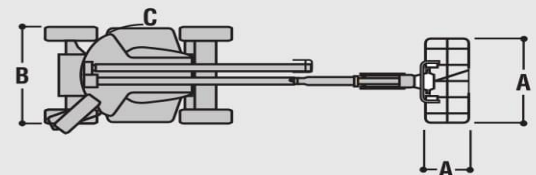
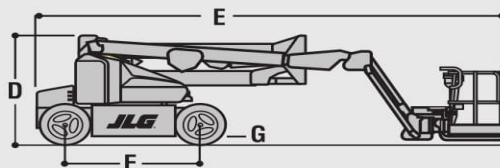

JLG is continually researching and developing products and reserves the right to make modifications without prior notice. All data in this document is indicative. Certain options or country standards will increase weight. Specifications may change to meet country standards or with the addition of optional equipment.

